

Items included:

- PS24-80W power supply , RS232 cable and connector
- Au Switchbox with cable and connector
- Table slot mounting screws, washers, nuts (4 sets)
- Table base mounting hardware
- Neorene splash guard, .06" x 12" x 12"

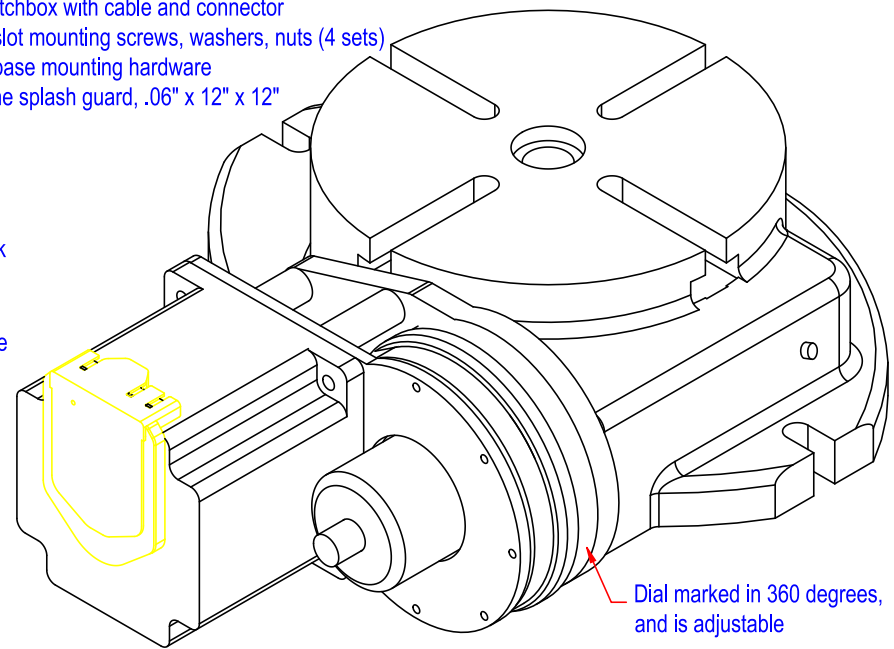

Motorized Rotary Table--see Au86 Series drawing for motor and controller details. MRT6 shown has 5:1 belt drive and precision ground 90:1 worm gears, 450:1 total ratio. Other ratios available, see www.excitron.com website. Weight is 54 pounds, ships in 2 boxes.

Motor Belt Assembly rotates 360° by loosening the single 10-32 screw. Motor can be rotated for best controller and connector position.

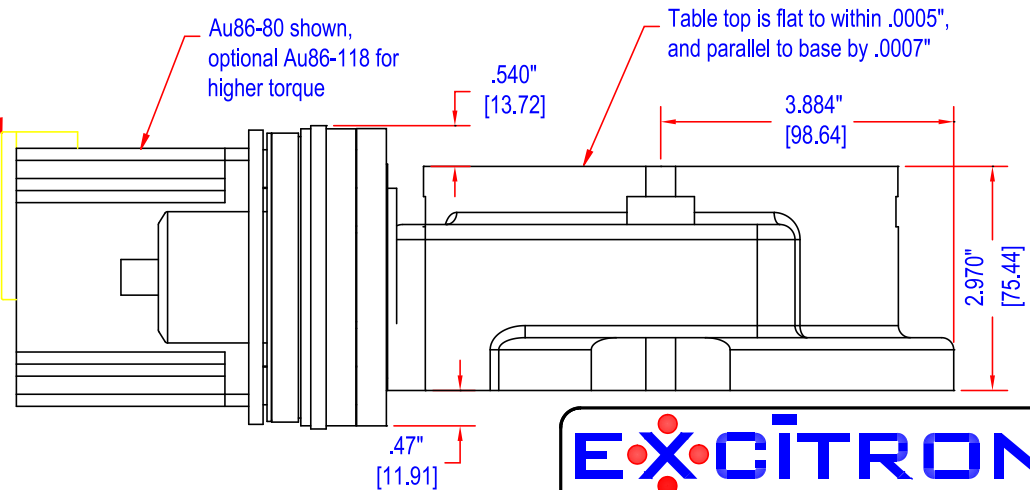
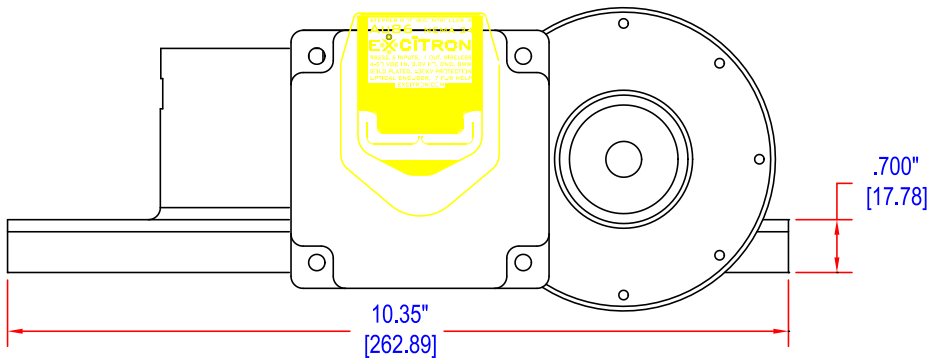

Warning--keep fingers from rotating belt and parts, injury may result. Suggest using the neoprene cover sheet when table is used for machining.

EXCITRON

5311 Western Ave #Q, Boulder, CO 80301
 info@excitron.com 303-859-9476

MRT6-86-80

www.excitron.com 40% 1/1 Rev. A