

Items included:

- PS24-80W power supply , RS232 cable and connector
- Au Switchbox with cable and connector
- Table slot mounting screws, washers, nuts (4 sets)
- Neorene splash guard, .06" x 12" x 12"
- Table base mounting hardware

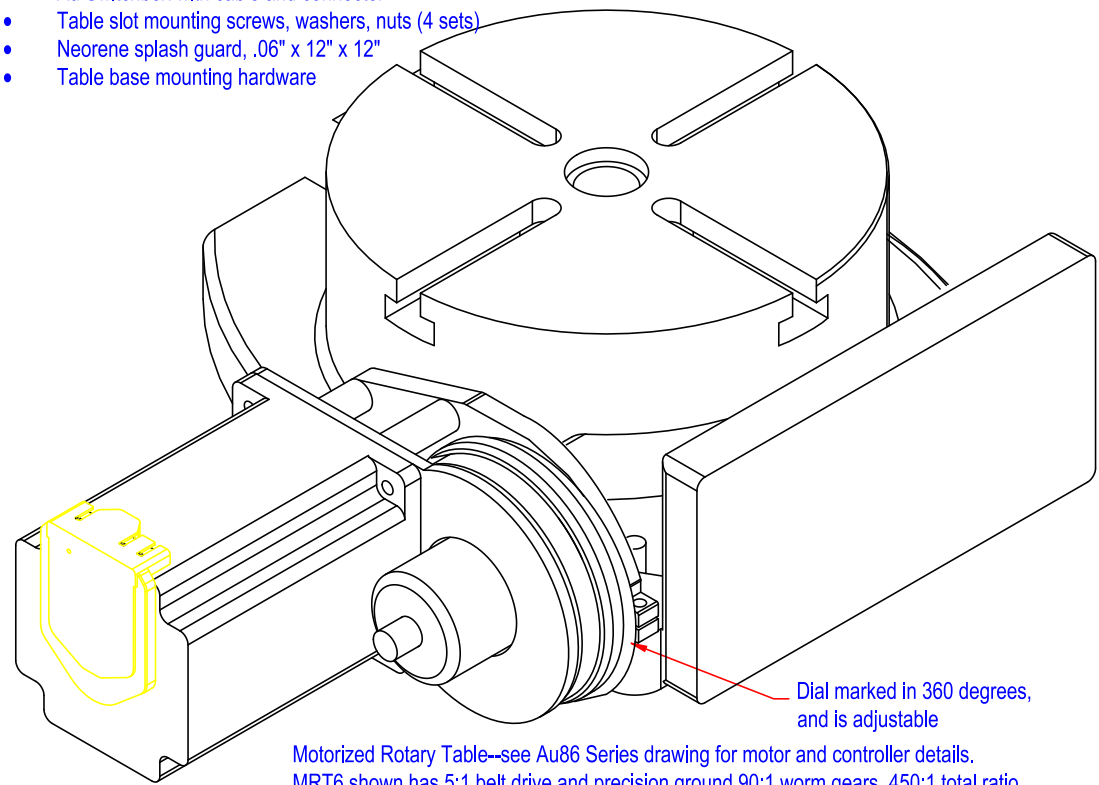

Motorized Rotary Table--see Au86 Series drawing for motor and controller details. MRT6 shown has 5:1 belt drive and precision ground 90:1 worm gears, 450:1 total ratio. Other ratios available, see www.excitron.com website. Weight is 54 pounds, ships in 2 boxes.

Lever to engage/disengage worm gear, allows free-wheeling of table.

Table top is flat to within .0005", and parallel to base by .0007"

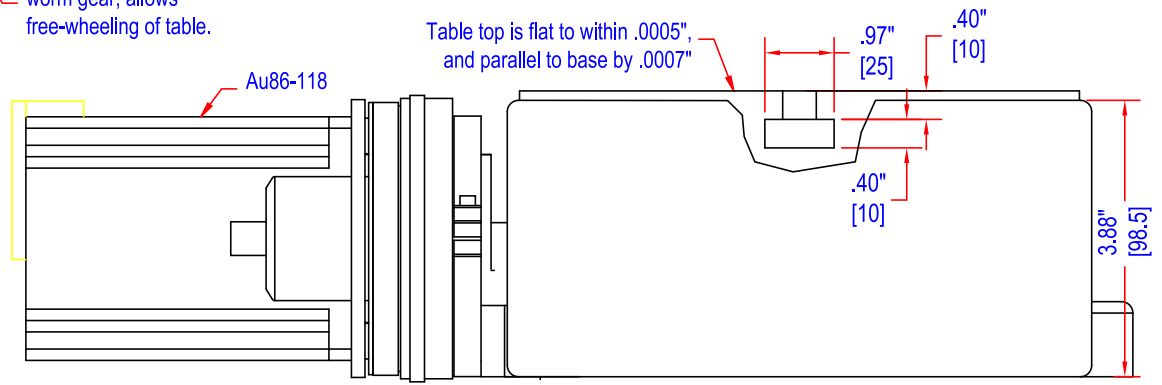

Au86 Controller/encoder (controller/driver/encoder)

Ø4.02" Dial [Ø102]

Warning--keep fingers from rotating belt and parts, injury may result. Suggest using the neoprene cover sheet when table is used for machining.

EXCITRON
 5311 Western Ave #Q, Boulder, CO 80301
 info@excitron.com 303-859-9476
MRT8-86-118HV
 www.excitron.com 37% 1/1 Rev. A