

MRT8-86-80 Motorized Rotary Table Key Features

- Precision ground heavy-duty worm gears with virtually zero backlash
- Perfect indexing to any degree with very high accuracy and repeatability
- Control speed, direction, angle, repeat action, and more
- 2 TTL serial ports, 4 Input Pins, and Step/Direction input pins
- Automatic repetitive motion possible, with time delays
- Ball bearings & Needle Roller Bearings
- Torque tested with 2 men standing on Table
- Table self-locks when motor is stopped, 2 locking levers included, but leave unlocked
- Complete ready-to-run kit

Items included but not shown:

- USB micro cable for control by smart phone!
- USB-TTL-3pin Adapter cable for smart phone or PC
- PS24-72W power supply, connector, AC cable, works anywhere in the world-100-240vac 50/60 hz
- Silicone clear splash guard, .02" x 12" x 18"
- 3X 4" Input cable 3 pin, open 1 end
- Table base mounting hardware
- 4 M10 Slot nuts
- Hex key ring with 1.5 to 10mm keys

Lock to adjust Eccentric Sleever worm gear play, and to engage/disengage

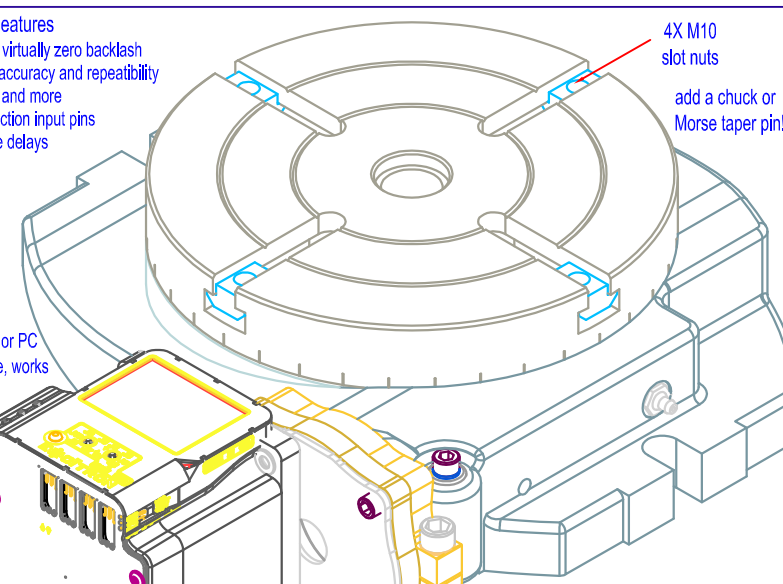

Rotary Table is pre-packed with Sinopec NLGI-2 Moly-Lithium high pressure grease, ok to use Harbor Freight Sta-Lube CRC SL3330 grease. Do not add oil which contaminates the grease. Suggest repacking Eccentric Collar Gear DC Power Jack Assembly with grease every 1,000 run hours. Remove worm gear drive assembly, squirt grease into small hole until excess comes out.

Optional Gear Kit p/n G86-486-90

Allows you to "shift gears" from 486:1 to 90:1 and vice versa, gives you 2 torque and speed choices. Use 486:1 for maximum resolution and torque for machining. Use 90:1 for higher speed.

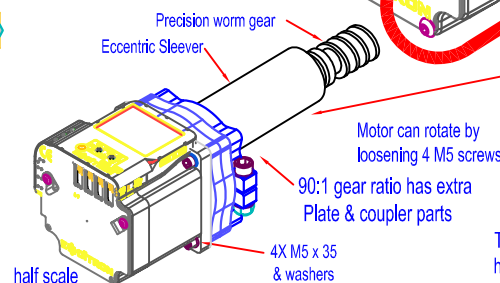
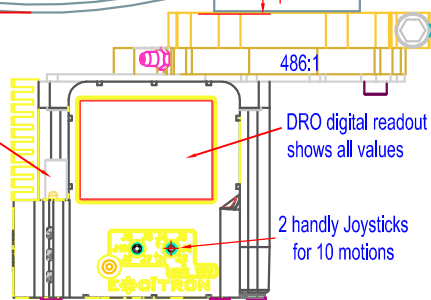

Ratio	RPM	Steps/rev	Step/°	Resolution	Ideal torque	Typ torque
90:1	8	36,000	100	.01000°	1,150 in-lb	600 in-lb
Best 486:1	2.4	194,400	540	.00185°	6,200 in-lb	3,100 in-lb

Torque is more than enough to mill steel with a Ø.500 cutter. Top speed of 8,000 motor half-steps/sec used in table, speed may be higher. Weight is 49 pounds, ships in 2 boxes.

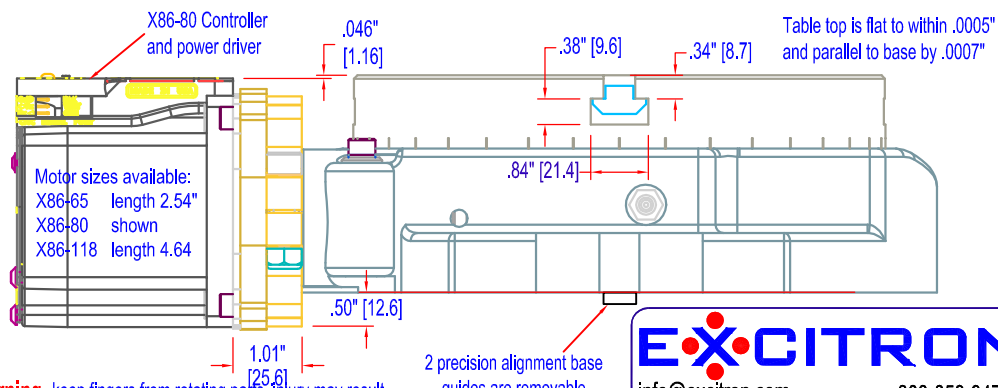
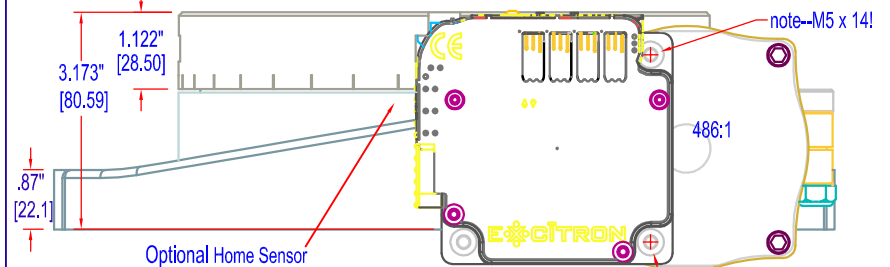

Ordering information:

Select MRT8-86-80 and specify the gear ratio you need-486 or 90. The basic MRT8-86-80 gives you one speed not both. For both 486:1 and 90:1 ratios, order the Optional Dual Gear Kit p/n G486-90.

Motor can rotate by loosening 4 M5 screws

Warning-keep fingers from rotating parts, injury may result.

See Rotary Tables product page and Documentation link for Controller Manual and X86 Series drawing for motor and controller details.



info@excitron.com

303-859-9476

MRT8-86-80