

- Items included:
- PS20-90W power supply with connector
 - RS232 6' cable and connector
 - Au I/O 9 wire cable open ended, for external control
 - Table slot mounting screws, washers, nuts (6 sets)
 - Neorene splash guard, .06" x 12" x 18"
 - Table base mounting hardware
 - 2 Base locking levers, not shown

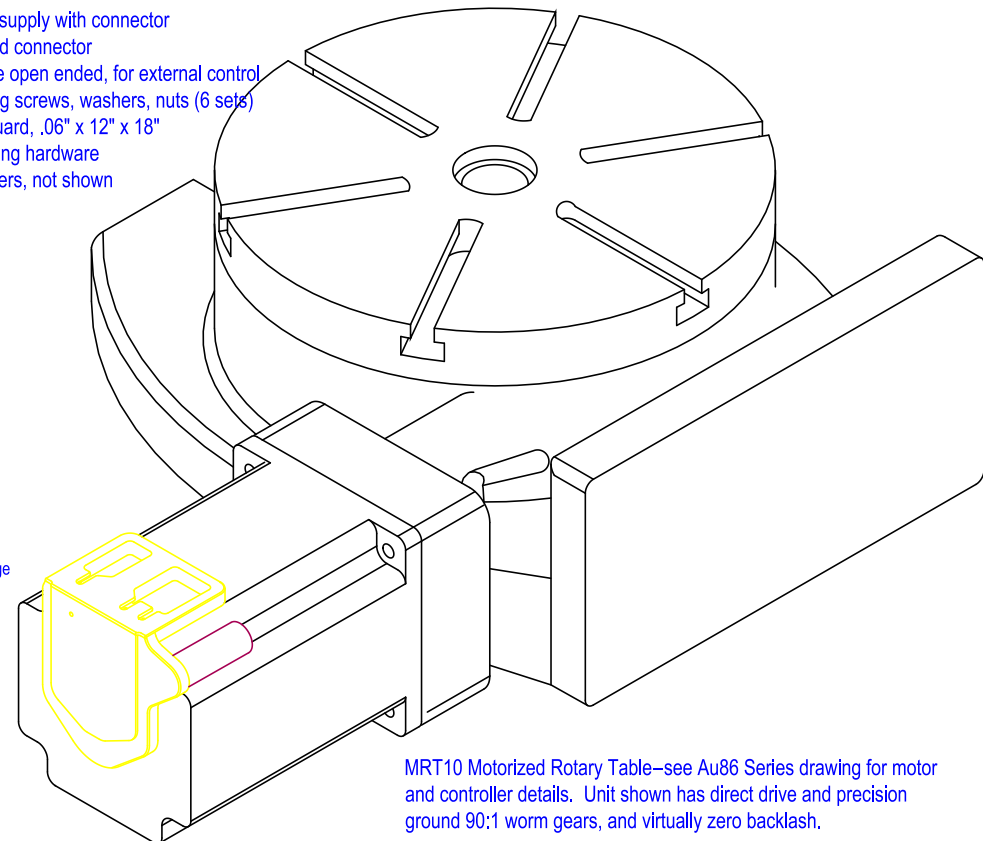

MRT10 Motorized Rotary Table—see Au86 Series drawing for motor and controller details. Unit shown has direct drive and precision ground 90:1 worm gears, and virtually zero backlash.

Theoretical torque is 3,000 in-lb, practical torque is 2,000 in-lb, more than enough to mill using a Ø.75 cutter through steel. Top speed of 8,000 motor half-steps/sec gives 15 rpm. Gear drive of 450:1 (2.7 rpm) also available, see www.excitron.com website. Weight is 98 pounds, ships in 2 boxes.

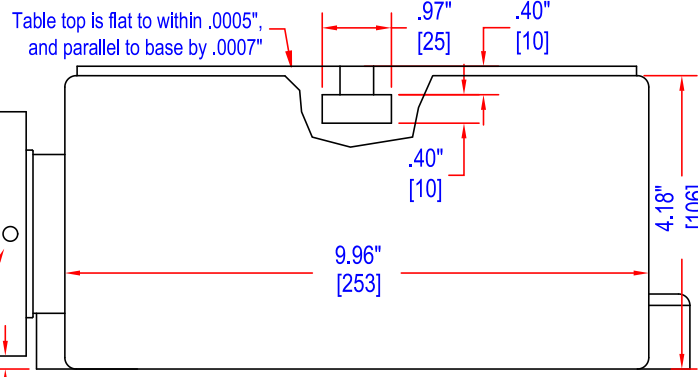

Motor Assembly rotates 360° by loosening the two M6 set screws.

Warning—keep fingers from rotating parts, injury may result. Suggest using the neoprene cover sheet when table is used for machining.

Warning—motors can cause severe injury. Specifications subject to change without notice.

Faster Than Fast!®

08/22/2011

EXCITRON
 info@excitron.com 303-859-9476
MRT10-86-118-90HV
 www.excitron.com ~37% 1/1 Rev. B