

- Items included:
- PS20-90W power supply with connector
  - RS232 6' cable and connector
  - Au I/O 9 wire cable open ended, for external control
  - Table slot mounting screws, washers, nuts (6 sets)
  - Neoprene splash guard, .06" x 12" x 18"
  - Table base mounting hardware
  - 2 Base locking levers, not shown

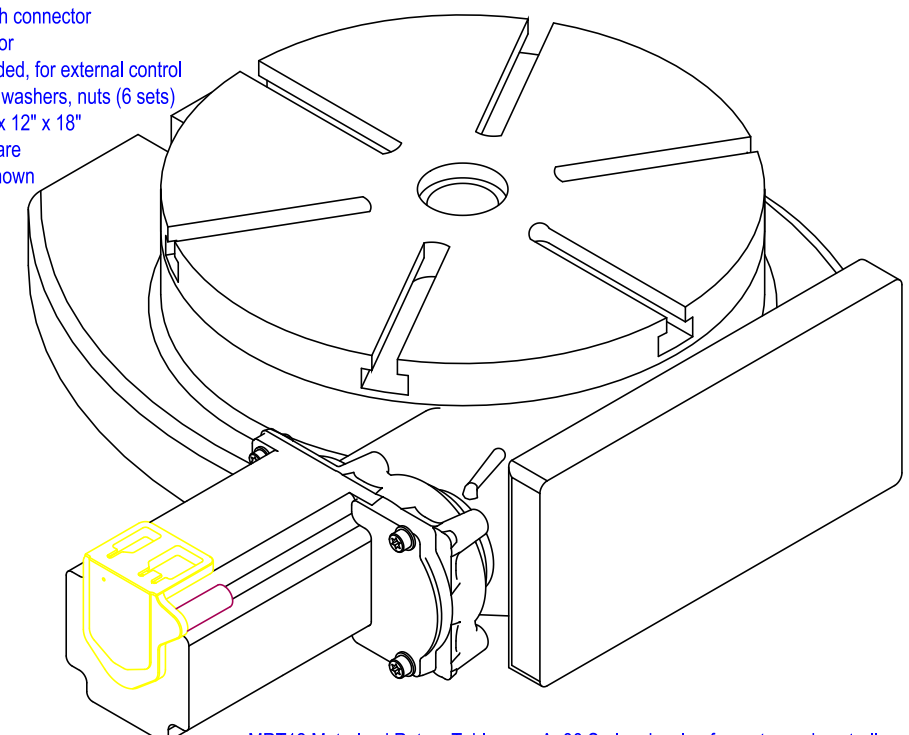

MRT12 Motorized Rotary Table--see Au86 Series drawing for motor and controller details. Unit shown has 5:1 gear drive and precision ground 90:1 worm gears, 450:1 total ratio, and virtually zero backlash.

Theoretical Torque is 15,000 in-lb, practical torque is 4,500 in-lb, more than enough to mill using a Ø1.00 cutter through steel. Top speed of 8,000 motor half-steps/sec gives 2.7 rpm. Straight drive of 90:1 (13 rpm) also available, see www.excitron.com website. Weight is 215 pounds, ships in 2-3 boxes.

Motor/Gearhead Assembly rotates 360° by loosening the two M5 set screws. Motor can be rotated for best controller and connector position, example:

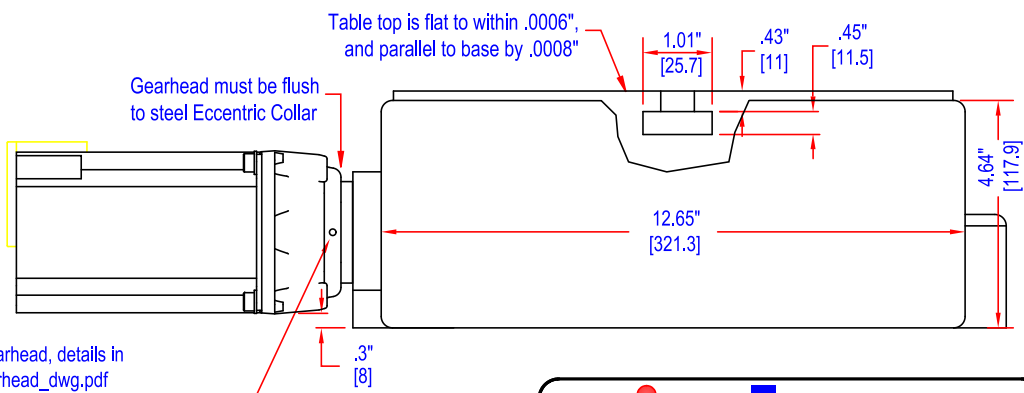
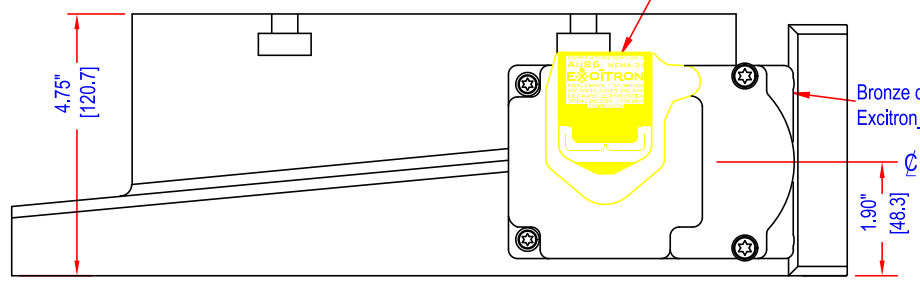
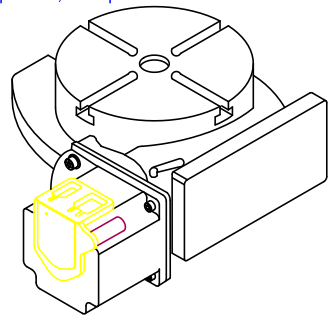

Table top is flat to within .0006", and parallel to base by .0008"

Gearhead must be flush to steel Eccentric Collar

Motor Assembly rotates 360° by loosening the two M5 set screws.

**Warning**--keep fingers from rotating parts, injury may result. Suggest using the neoprene cover sheet when table is used for machining.

**EXCITRON**  
 info@excitron.com 303-859-9476  
**MRT12-86-156-450HV**  
 www.excitron.com ~25% 1/1 Rev. B